

**Model** : Finisher D1

**Ref. No.** : FF-T01-W-000051-02

**Date** : July 2, 1999

**REVISED**

FF-T01-W-000051-01(March 31, 1999); Affected machine numbers, ①×1 on p. 3.

© Canon (UK) Limited

**Location** : SORTING GUIDE ASSEMBLY

**Subject** : PREVENTING STATIONARY JAMS IN THE FINISHER-D1 (AROUND THE SORTING GUIDE)

**Reason** : Paper can hit the ribs in the sorting guide assembly to jam, and the problem can be corrected by providing the measures shown herein during servicing work.

**Details** : <Symptom>  
Depending on the type (degree of body) and how it is moved, paper can hit the ribs in the sorting guide assembly to jam (stationary) in front of the sorting guide.

<Cause>

The absence of a gap between the ribs in the sorting guide assembly and passing paper hinders the paper from moving properly, resulting in a stationary jam in front of the sorting guide.

<Factory measure>

A spacer is attached to the ribs in the sorting guide to create a clearance between the ribs and passing paper, thereby ensuring smooth passage of paper.

**Servicing** : < Making Checks and Providing Measures >

1. If the delivery outlet tray is in the way, change its location.

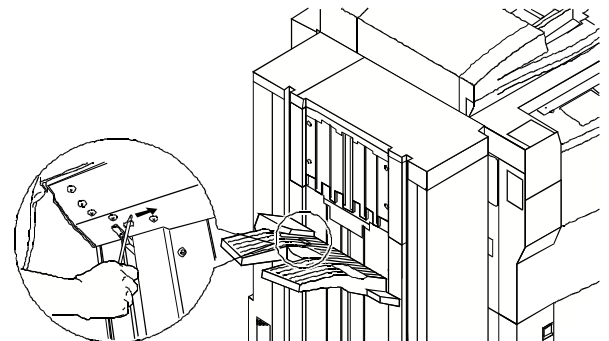

Fig. 1

2. While holding up the swing guide, check the gap between the sorting guide assembly and the ribs. If the gap is not as indicated, perform the following steps:

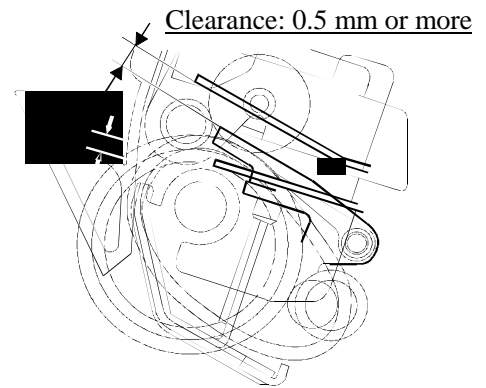

Fig. 2

3. Remove the four screws, and detach the stacking wall (upper) of the Finisher-D1.

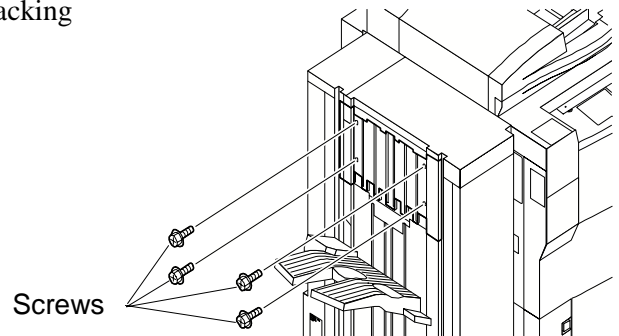

Fig. 3

4. Remove the processing tray unit. (See pp. 3-13 through -14 in the Service Manual; FY8-13FF-000.)
  - 1) Remove the screw, and detach the sorting tray stopper.
  - 2) Move up the sorting tray to its upper limit by hand. (See the descriptions on the ascent of the sorting tray.)
  - 3) Remove the four screws, and detach the stacking wall (lower).
  - 4) Remove the screw, and detach the connector cover. (See Figure 4.)

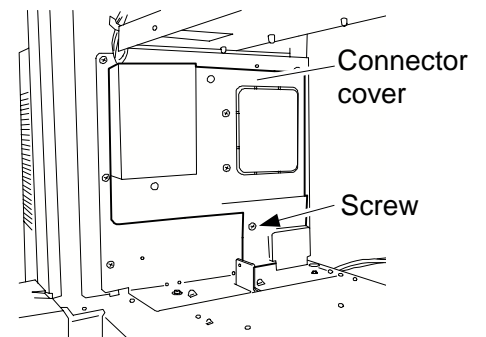

Fig. 4

- 5) Remove the seven connectors, and free the harness from the cord clamp.

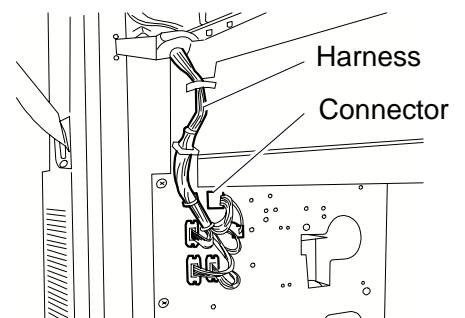

Fig. 5

- 6) Remove the four fixing screws, and detach the processing tray unit.

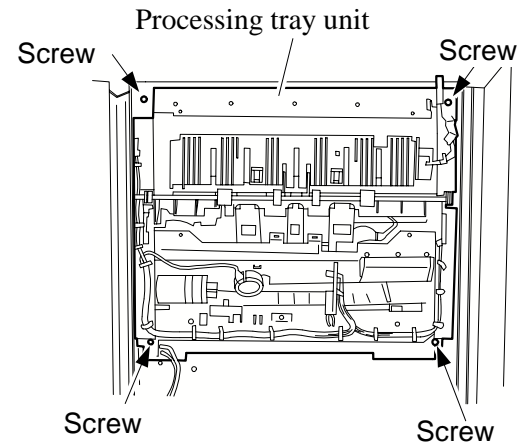

Fig. 6

5. Attach the 0.25-mm spacer to the sorting guide assembly so that the ribs will lower.

**Note:** If one is not enough, attach another spacer over it.

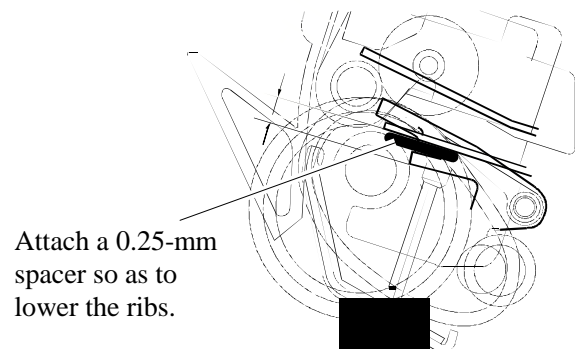

Fig. 7

6. Check to make sure that the standard is satisfied.

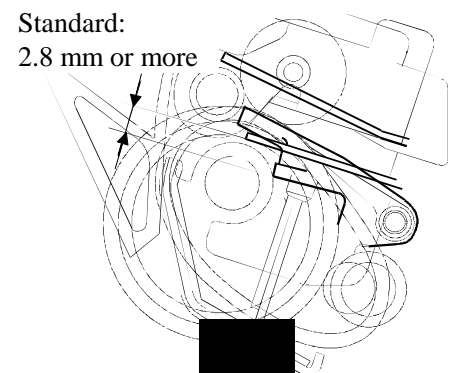

Fig. 8

7. Mount the processing tray unit.
8. Mount the stacking walls (upper, lower).
9. Mount the sorting tray stopper.

**Affected machines:**

- ① ➔ To be communicated as soon as the information becomes available.  
 NLF00229 and later                      ULF00316 and later